

ADA Manual

Simplified ADA Railing System

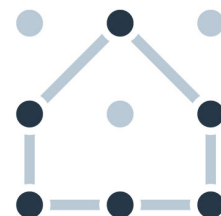

SIMPLIFIED
BUILDING

For assistance visit: www.simplifiedbuilding.com/ada-handrail or call 1.888.527.2278

TABLE OF CONTENTS

How To Use This Manual	1
Which Drawing Do I Use?	1
Recommended Tools	2
Needed Materials	2
Installation Tips	2
Basic Principals Of ADA	3
DIAGR AM: Top, Middle & Bottom Rail	4
Top, Middle, & Bottom Railing Detail	4
DIAGRAM: Top & Bottom Rail	5
Top & Bottom Railing Detail	5
Additional Diagrams	6

HOW TO USE THIS MANUAL

This manual is not meant to provide comprehensive, step-by-step instructions for installing your specific railing. Each railing is different in application and arrangement. This manual is designed to give you the general principals necessary for installing a Simplified ADA Railing. Please read the basic principals and then refer to the install guide that is most relevant to your application.

WHICH DRAWING DO I USE?

Use the table below to determine which drawing(s) in this manual will be of the greatest help to you.

Top Rail ADA Railing (ignore bottom rail)	Page 5
Top & Mid Rail ADA Railing (ignore bottom rail)	Page 4
Top, Mid & Bottom Railing	Page 4
Top & Bottom Railing Stair	Page 5
Railing	Page 4
Wall Attachment	Page 4 & 6



RECOMENDED TOOLS

ALLEN WRENCH

Both a 1/4" and 5/16" allen wrench are required for tightening set screws in the fittings

SAW TO CUT PIPE

- Chop Saw
- Band Saw
- Reciprocating Saw(Sawzall)

DRILL

- Hammer drill may be needed when drilling into brick or concrete

NEEDED MATERIALS

SELF DRILLING SCREWS (NO. 12) OR MULTI-GRIP POP RIVETS

For attaching handrail to brackets

MOUNTING HARDWARE FOR BASE FLANGES

- 1/4" For Wall Mounts
- 1/2" For Base Flanges

RECOMENDATIONS:

- Lag Screws
- Chemical Anchors
- Tapcons
- Sleeve Anchors

INSTALLATION TIPS

- Cut the pipe at the job site.
- Use base flanges instead of core drilling to prevent rust to posts.
- Center posts no more than 6' from each other.
- Base flanges should be placed 5" on center from edge of concrete.
- Posts must be offset between 8"-18" from corners and angles in the railing.

BASIC PRINCIPLES OF ADA

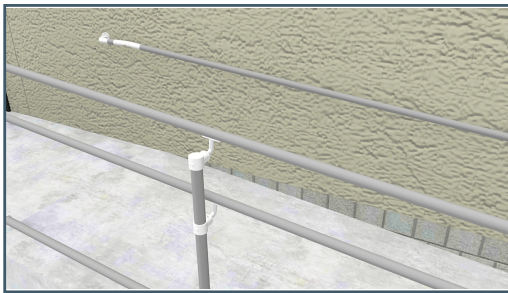
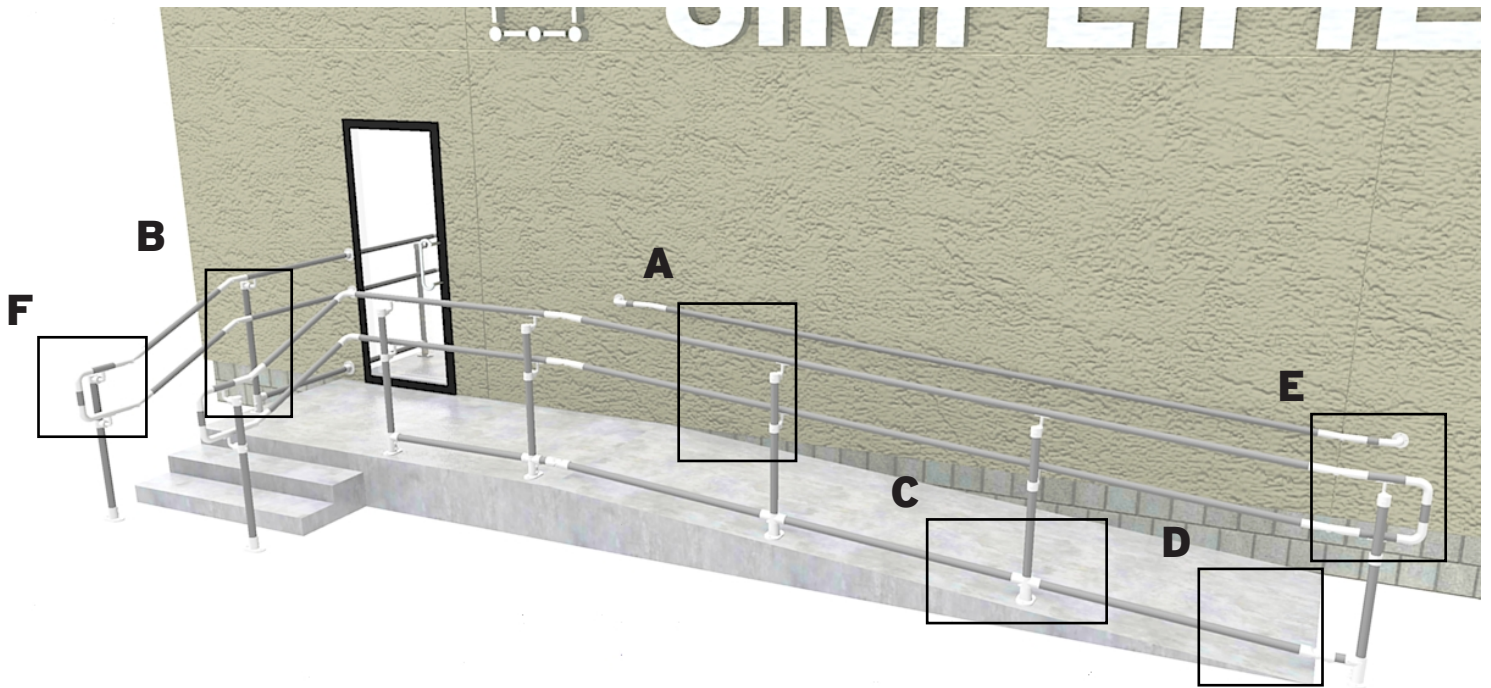

A) RAILING: Railing must be a continuous smooth surface. A railing must be on both sides of ramp or stairs.

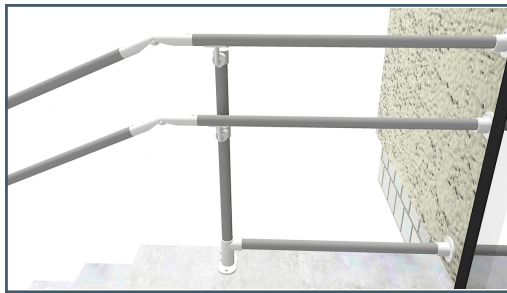

B) RAILING HEIGHT: Top of railing must be 34"- 38" above the floor.

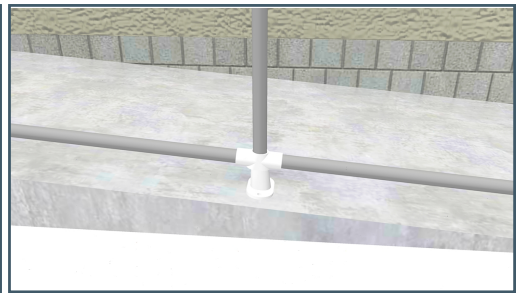

C) EDGE PROTECTION: When there is a drop off, ramps more than 6' long require a curb or curb rail 4" above the floor.

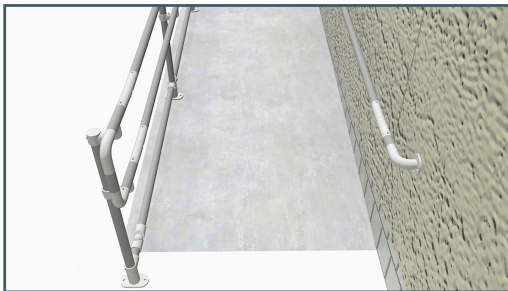

D) CLEARANCE: A ramp must have a minimum clear width of 36".

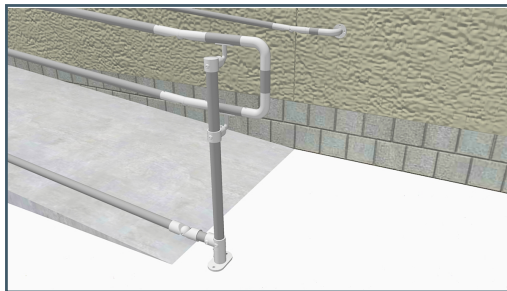

E) D RETURNS: Railing ends need to be rounded or return smoothly into a floor, wall or post.

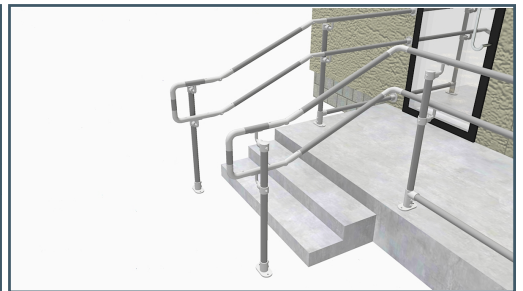

F) EXTENSIONS: Stairs: Railing should extend past the bottom step a minimum distance of one stair tread. Ramps: Railing should extend parallel to walking surface 12" past the top and bottom of the ramp.

DIAGRAM 1: TOP, MIDDLE, & BOTTOM RAIL

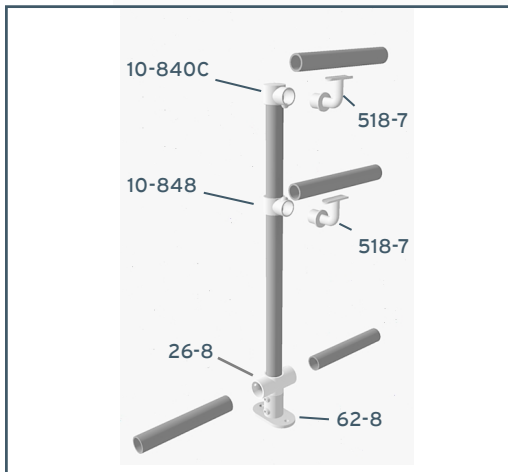
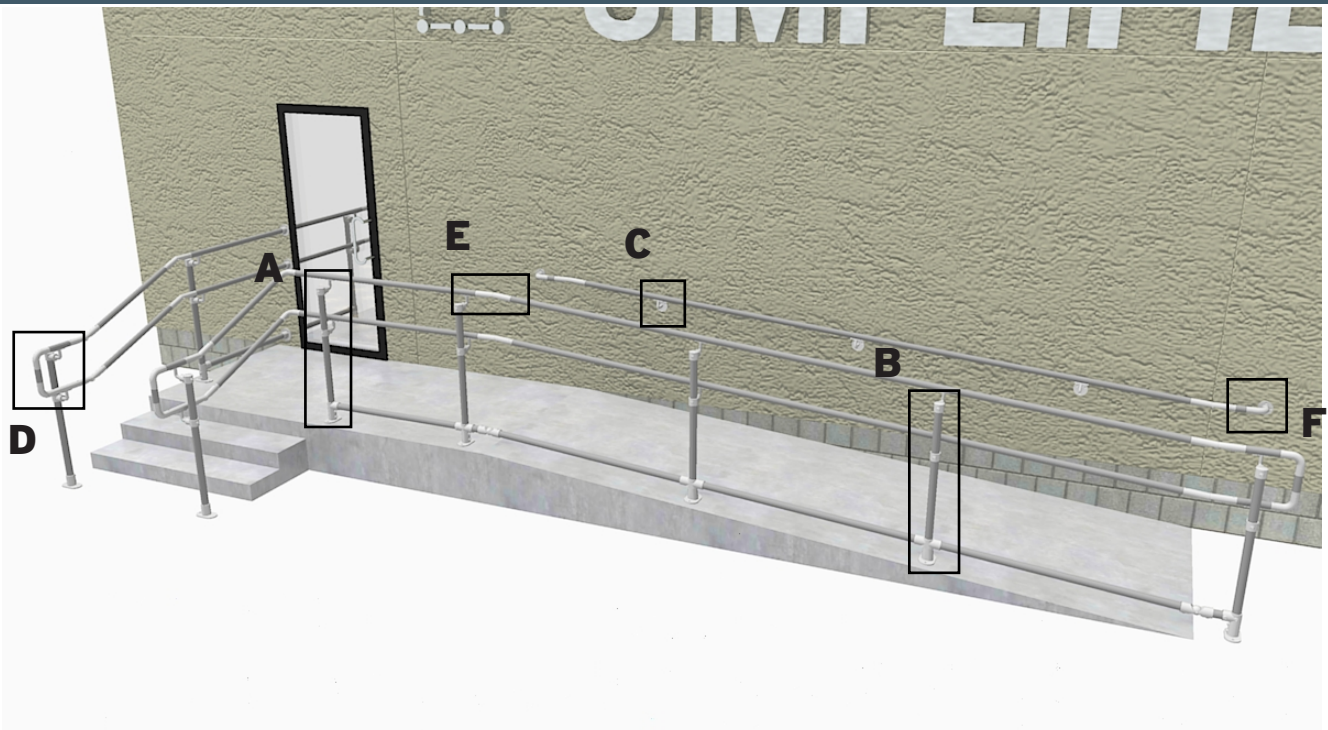

A) STANDARD UPRIGHT: The 62-8 base flange is for mounting to level surfaces. The 518-7 connects to 10-848 and 10-840C fitting.

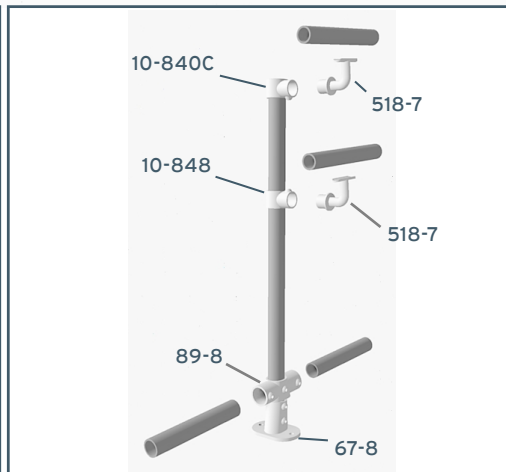

B) RAMP UPRIGHT: The 67-8 base flange is for mounting to angled surfaces. The angle is fixed by tightening the set screws. The railings are attached in the same manner as the Standard Upright. The bottom rails are connected with 89-8 on mids and 86-8 on ends.

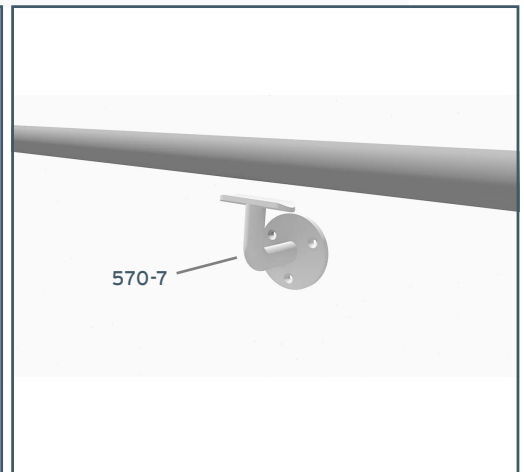

C) WALL MOUNT: The 570-7 is connected to the wall or wood posts using 1/4" screws or bolts. The 570-7 is attached to the railing with No. 12 self-drilling screws or pop rivets.

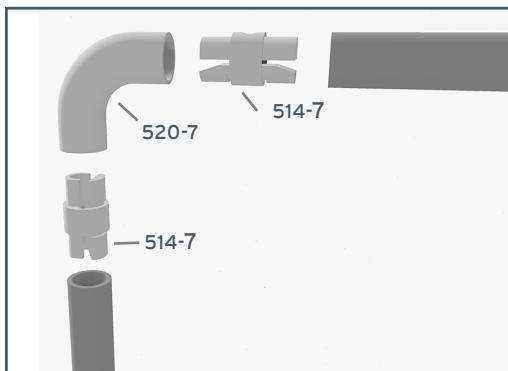

D) D RETURNS: D returns are constructed with 520-7s and 514-7. The 520-7s are connected vertically with a small piece of pipe. This assembly is then joined to the top and midrail with 514-7s.

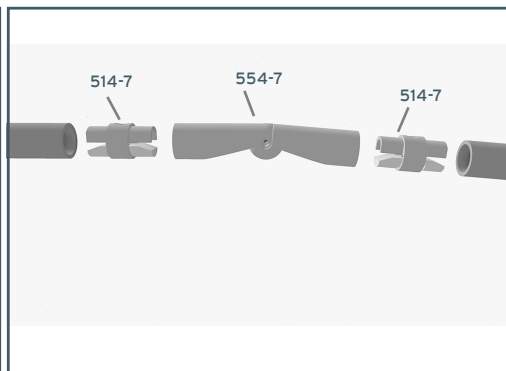

E) ADJUSTABLE ANGLES: In order to accomplish angles with a smooth surface, use the 554-7 and 514-7s. These are frequently used at the top and bottom of ramps and stairs.

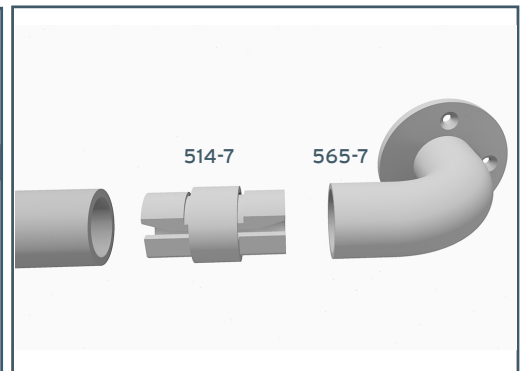

F) WALL RETURN: The 565-7 wall return flange is connected to the wall and then connected to the pipe with a 514-7.

DIAGRAM 2: TOP & BOTTOM RAIL

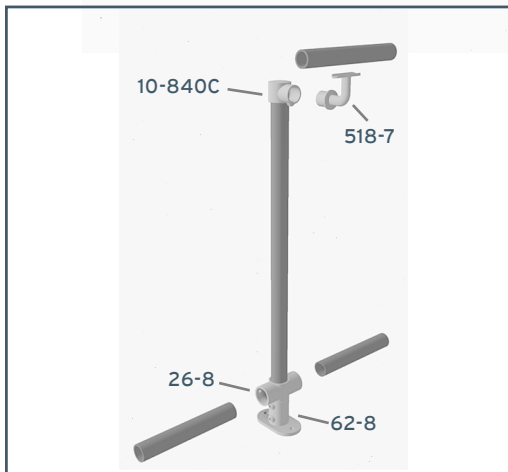
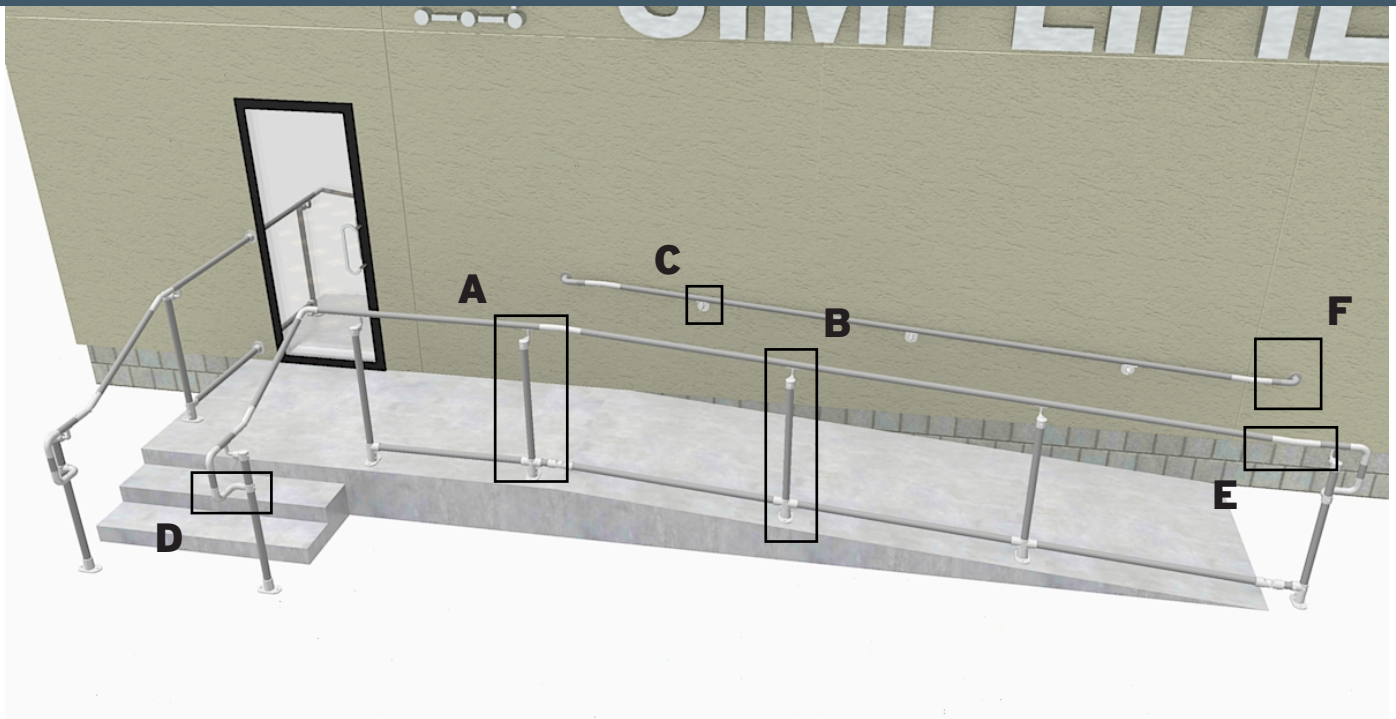

A) STANDARD UPRIGHT: The 62-8 base flange is for mounting to level surfaces. The 518-7 connects the railing to the 10-840C fitting.

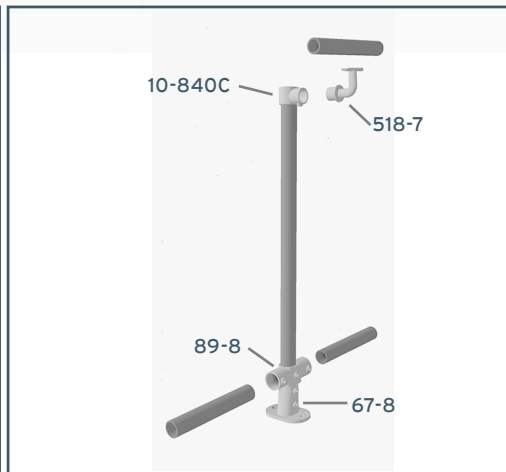

B) RAMP UPRIGHT: The 67-8 base flange is for angled surfaces. The upright angle is fixed by tightening the set screws. The railings are attached in the same manner as the Standard Upright. The bottom rails are connected with 89-8 on mids and 86-8 on ends.



C) WALL MOUNT: The 570-7 is connected to the wall or wood posts using 1/4" screws or bolts. The 570-7 is attached to the railing with No. 12 self-drilling screws.

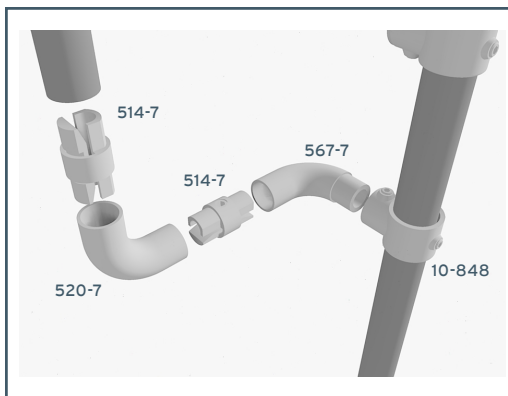

D) POST RETURN D-RETURN: The D-return connects to the post using the 567-7 and 10-848. The 10-848 receives the small end of the 567-7. The 567-7 is then joined to the 520-7 using a 514-7.



E) ADJUSTABLE ANGLES: In order to accomplish angles with a smooth surface, use the 554-7 and two 514-7. These are frequently used at the top and bottom of ramps and stairs.

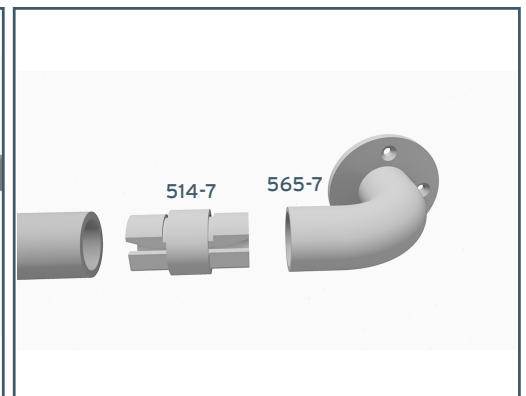

F) WALL RETURN: The 565-7 wall return flange is connected to the wall or wooden posts with 1/4" screws or bolts. It is then connected to the pipe with a 514-7.

APPENDIX: ADDITIONAL DIAGRAMS

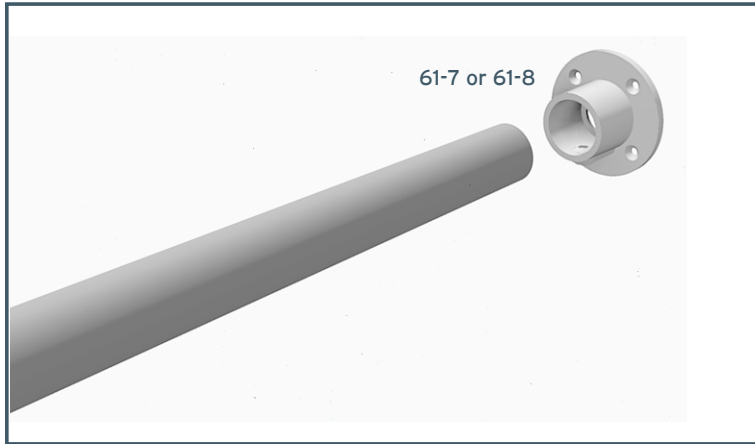

Railing Wall Termination: Connect the end of the railing to a wall using the type 61 flange. Use 61-7 for Top and Mid rails, and 61-8 for the bottom rail.

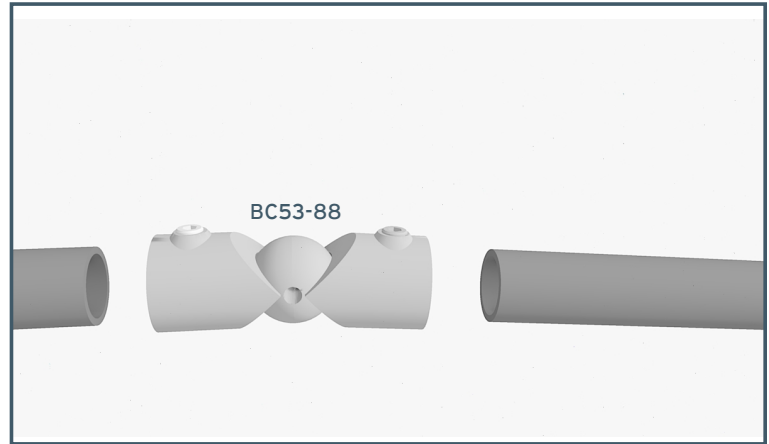

BOTTOM RAIL ANGLE CHANGE: The angle change on the bottom rail of a ramp is typically done using a BC53-8 or a 55-8.



Supporting joints: All elbows and angles should be supported with a post no further than 18 inches from the join.

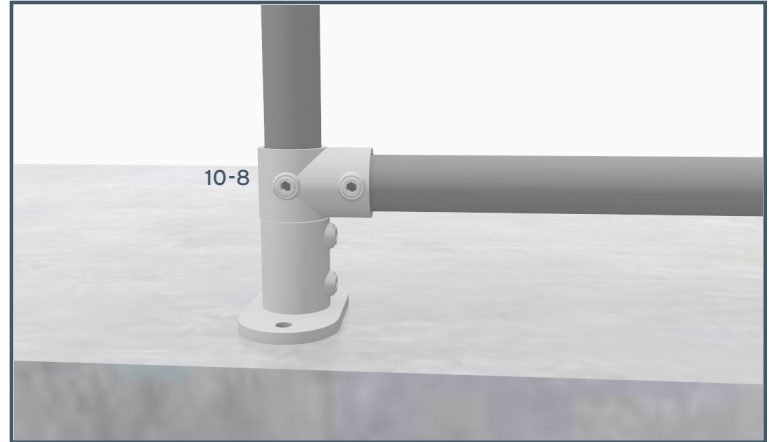

POST MOUNTED BOTTOM RAIL END: The bottom rail on a flat surface terminates into a railing post using a 10-8.



RAILING END: Mount the 561-7 to the wall. The handrail or mid-rail pipe is then connected to this fitting using a 514-7.



HANDRAIL BRACKET ATTACHMENT: Brackets attach to the handrail pipe with two No. 12 self drilling screws or pop rivets. Use high quality hardware for the best results.